



T3

Orbital

Automatic Scrubber

English **EN**
Operator Manual

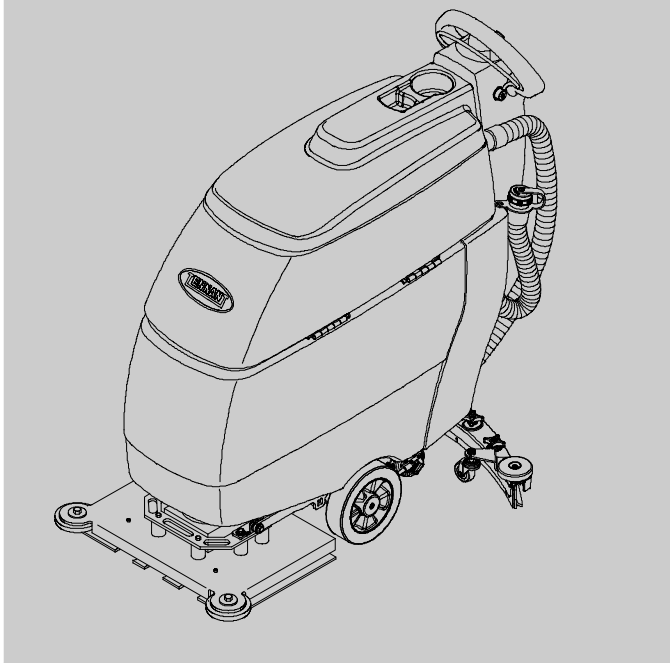

Model Part No:
9009981 Conventional Scrubber
9009980 ec-H₂O Scrubber



Hygenic® Fully Cleanable Tanks

North America



To view, print or download
the latest manual, visit:

www.tennantco.com/manuals

9010337
Rev. 00 (12-2012)



OPERATION

INTRODUCTION

This manual is furnished with each new model. It provides necessary operation and maintenance instructions.



Read this manual completely and understand the machine before operating or servicing it.

This machine will provide excellent service. However, the best results will be obtained at minimum costs if:

- The machine is operated with reasonable care.
- The machine is maintained regularly - per the machine maintenance instructions provided.
- The machine is maintained with manufacturer supplied or equivalent parts.

Parts and supplies may be ordered online, by phone, by fax or by mail.

MACHINE DATA

Please fill out at time of installation for future reference.

Model No. - _____

Serial No. - _____

Machine Options - _____

Sales Rep. - _____

Sales Rep. phone no. - _____

Customer Number - _____

Installation Date - _____



PROTECT THE ENVIRONMENT

Please dispose of packaging materials, old machine components, and fluids in an environmentally safe way according to local waste disposal regulations.



Always remember to recycle.

INTENDED USE

This walk behind orbital scrubber is intended for commercial use, for example in hotels, schools, hospitals, factories, shops, offices, and rental businesses. It is designed to scrub floors in an indoor environment and is not constructed for any other use. Use only recommended pads and commercially available floor cleaners intended for machine application. Do not use flammable liquids with this machine. This machine is not intended for cleaning carpets or sanding wood floors.

TENNANT Company

PO Box 1452

Minneapolis, MN 55440

Phone: (800) 553-8033 or (763) 513-2850

www.tennantco.com

Specifications and parts are subject to change without notice.

Original Instructions Copyright © 2012 TENNANT COMPANY, Printed in U.S.A. All rights reserved.

TABLE OF CONTENTS

SAFETY PRECAUTIONS	4	MACHINE MAINTENANCE	19
SAFETY LABELS	5	DAILY MAINTENANCE	19
MACHINE COMPONENTS	6	MONTHLY MAINTENANCE	21
CONTROL PANEL SYMBOLS	7	MOTOR MAINTENANCE	21
MACHINE INSTALLATION	7	ec-H ₂ O MODULE FLUSH PROCEDURE ...	21
UNCRATING MACHINE	7	SQUEEGEE BLADE REPLACEMENT	22
INSTALLING BATTERIES	7	SQUEEGEE BLADE ADJUSTMENT	23
HOW THE MACHINE WORKS	8	BATTERY MAINTENANCE	23
PAD INFORMATION	9	TRANSPORTING MACHINE	24
MACHINE SETUP	9	STORING MACHINE	24
ATTACHING SQUEEGEE ASSEMBLY	9	FREEZE PROTECTION	24
INSTALLING BACKER PAD AND WORK PAD	10	TROUBLESHOOTING	26
FILLING SOLUTION TANK	10	BATTERY METER LED FAULT CODES	28
MACHINE OPERATION	11	SPECIFICATIONS	29
PRE-OPERATION CHECKS	11	MACHINE DIMENSIONS	30
OPERATING THE MACHINE	11		
WHILE OPERATING MACHINE	12		
BATTERY METER	13		
CIRCUIT BREAKER / FUSES	14		
HOUR METER	14		
DRAINING TANKS	14		
DRAINING RECOVERY TANK	14		
DRAINING SOLUTION TANK	15		
CHARGING BATTERIES	16		
BATTERY CHARGER SPECIFICATIONS: ..	16		
USING THE ON-BOARD BATTERY			
CHARGER	16		
ON-BOARD BATTERY CHARGER FAULT			
CODES	18		

IMPORTANT SAFETY INSTRUCTIONS - SAVE THESE INSTRUCTIONS

The following warning alert symbol and the “FOR SAFETY” heading are used throughout this manual as indicated in their description:

⚠ WARNING: To warn of hazards or unsafe practices which could result in severe personal injury or death.

FOR SAFETY: To identify actions which must be followed for safe operation of equipment.

The following safety precautions signal potentially dangerous conditions to the operator or equipment. All operators must read, understand and practice them.

⚠ WARNING: Fire Or Explosion Hazard:

- Never Use Flammable Liquids Or Operate Machine in Or Near Flammable Liquids, Vapors Or Combustible Dusts.

This machine is not equipped with explosion proof motors. The electric motors will spark upon start up and during operation which could cause a flash fire or explosion if machine is used in an area where flammable vapors/liquids or combustible dusts are present.

- Do Not Pick Up Flammable Materials Or Reactive Metals.
- Batteries Emit Hydrogen Gas. Keep Sparks And Open Flame Away. Keep Battery Compartment Open When Charging.

⚠ WARNING: Electrical Hazard

- Disconnect Battery Cables and Charger Plug Before Servicing Machine.
- Do Not Charge Batteries with Damaged Power Supply Cord. Do Not Modify Plug.

If the charger supply cord is damaged or broken, it must be replaced by the manufacturer or its service agent or a similarly qualified person in order to avoid a hazard.

FOR SAFETY:

1. Do not operate machine:
 - With flammable liquids or near flammable vapors as an explosion or flash fire may occur.
 - Unless trained and authorized.
 - Unless operator manual is read and understood.
 - If not in proper operating condition.
 - Unless mentally and physically capable of following machine instructions.
 - In areas that are too dark to safely see the controls or operate the machine.
2. Before starting machine:
 - Check machine for fluid leaks.
 - Make sure all safety devices are in place and operate properly.
3. When using machine:
 - Use only as described in this manual.
 - Go slow on inclines and slippery surfaces.
 - Wear non-slip shoes.
 - Reduce speed when turning.
 - Report machine damage or faulty operation immediately.
 - Never allow children to play on or around.
 - Do not operate on inclines that exceed 5%.
 - Follow mixing, handling and disposal instructions on chemical containers.
 - Follow safety guidelines concerning wet floors.
4. Before leaving or servicing machine:
 - Stop on level surface.
 - Turn off machine.
 - Remove key.
5. When servicing machine:
 - Avoid moving parts. Do not wear loose clothing, jewelry and secure long hair.
 - Disconnect battery connections before working on machine.
 - Wear protective gloves and eye protection when handling batteries or battery cables.
 - Avoid contact with battery acid.
 - Wear protective gloves and eye protection when handling white vinegar.
 - Do not power spray or hose off machine. Electrical malfunction may occur.

- All work must be done with sufficient visibility and lighting.
 - Wear personal protection equipment as needed and where recommended in this manual.
 - Wear a dust mask, protective glasses and gloves in dusty environments.
 - Keep work area well ventilated.
 - Use manufacturer supplied or approved replacement parts.
 - All repairs must be performed by a qualified service person.
 - Do not modify the machine from its original design.
6. When loading/unloading machine onto/off truck or trailer:
 - Drain tanks before loading.
 - Use a ramp that can support the machine weight and person loading it. Do not exceed a 15% ramp incline at a ramp length of 12 ft (3.7m).
 - Turn machine off.
 - Put scrub head in the lowered position.
 - Block machine wheels.
 - Use tie-down straps to secure machine.
 - Set parking brake, if equipped.

SAFETY LABELS

The safety labels appear on the machine in the locations indicated. Replace labels if they are missing or become damaged or illegible.

WARNING LABEL - Located on recovery tank cover.

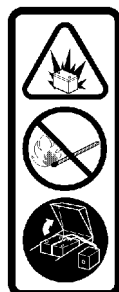

BATTERY CHARGE LABEL - Located near battery compartment.

⚠️ WARNING: Fire Or Explosion Hazard. Batteries Emit Hydrogen Gas. Keep Sparks And Open Flame Away. Keep Battery Compartment Open When Charging.





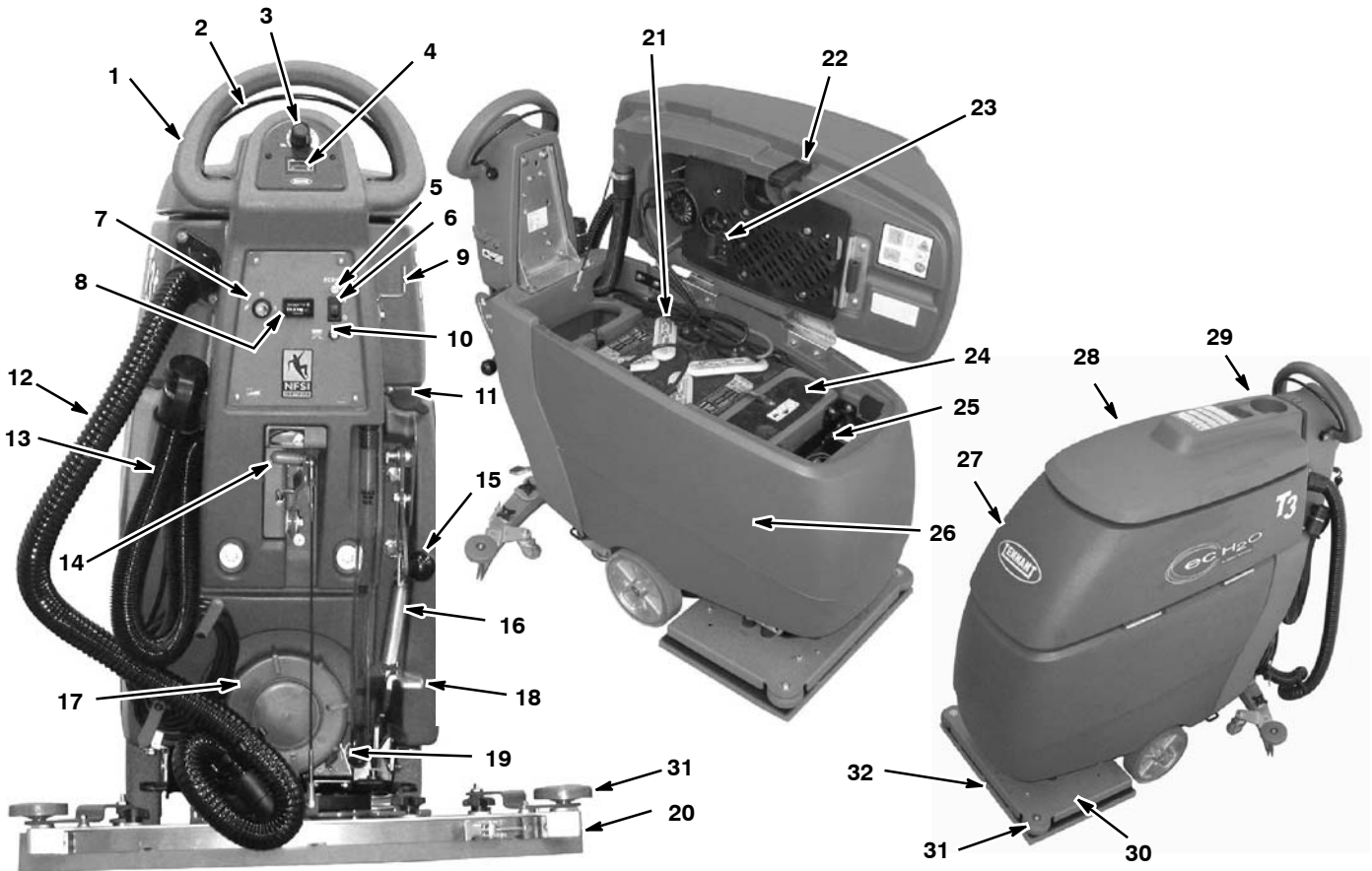



OPERATION

MACHINE COMPONENTS



1. Control Handle
2. Control Handle Start Bail
3. Speed Control Knob
4. Battery Meter
5. *ec-H2O* system indicator light (*ec-H2O* Model)
6. *ec-H2O* system on/off switch (*ec-H2O* Model)
7. Main Power Key Switch
8. Hour Meter
9. Squeegee Storage Bracket
10. Pad Driver Motor Circuit Breaker Button
11. Hose Fill-Port
12. Vacuum Hose
13. Recovery Tank Drain Hose
14. Squeegee Lift Lever
15. Heavy Down Pressure Lever
16. Solution Tank Level/Drain Hose
17. Solution Tank Clean-Out Port
18. Scrub Head Lift Pedal
19. Solution Flow Control Knob
20. Squeegee Assembly
21. Batteries
22. Recovery Tank Support Stand
23. On-board Battery Charger
24. Bucket Fill Port/Clean-out Port
25. *ec-H2O* System Module (*ec-H2O* Model)
26. Solution Tank
27. Recovery Tank
28. Recovery Tank Cover
29. Cup Holder
30. Scrub Head
31. Wall Rollers
32. Backer Pad/Work Pad

CONTROL PANEL SYMBOLS

	Main Power I/O Key Switch		ec-H2O System I/O Switch (ec-H2O Model)		5% Maximum Machine Climb
	Slow Speed		Pad Motor Circuit Breaker		Solution Flow Control
	Fast Speed		Bail Direction		Heavy Scrub Pad Down Pressure

MACHINE INSTALLATION

UNCRATING MACHINE

- Carefully check the shipping crate for signs of damage. Report damages at once to carrier.
- Check the contents list. Contact distributor for missing items.
Contents:
 - 2-12 V Batteries - Optional
 - 2-Foam Battery Spacers (#630375)
 - Battery Tray (#1012994)
 - 15 in / 38 cm Battery Cable (#130364)
 - 4-Battery Cable Rubber Boots
 - Squeegee Assembly (#9001178)
- To uncrate your machine, remove the shipping hardware and straps that secure the machine to the pallet. With assistance, carefully lift the machine off the pallet.

ATTENTION: Do not roll machine off pallet unless a ramp is used, machine damage may occur.

ATTENTION: To prevent possible machine damage, install batteries after removing machine from shipping pallet.

INSTALLING BATTERIES

⚠ WARNING: Fire Or Explosion Hazard. Batteries Emit Hydrogen Gas. Keep Sparks And Open Flame Away. Keep Battery Hood Open When Charging.

FOR SAFETY: When servicing machine, wear protective gloves and eye protection when handling batteries and battery cables. Avoid contact with battery acid.

Battery Specifications:

Two 12 volt deep cycle lead acid batteries.

155 AH battery - 20 in / 50cm

Maximum battery dimensions: 6.85 in / 174 mm W x 15 in / 380 mm L x 11.18 in / 284 mm H.

- Park the machine on a level surface and remove the key.
- Lift the recovery tank to access the battery compartment (Figure 1).



FIG. 1

OPERATION

- Carefully install the batteries into the battery compartment tray and arrange the battery posts as shown (Figure 2). Insert the two foam spacers along side the batteries as shown.

ATTENTION: Do not drop the batteries into the compartment, battery and machine housing damage may result.

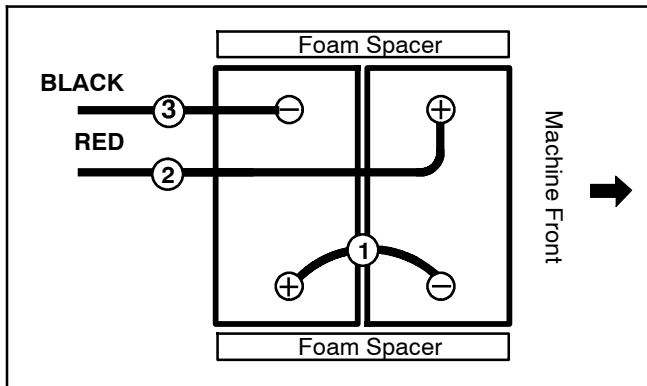

FIG. 2

- Using the supplied battery post boots, connect the cables to the battery posts in numerical order as labeled (Figure 2), RED TO POSITIVE (+) & BLACK TO NEGATIVE (-).

IMPORTANT: Make sure that the charger is properly set for your battery type before charging (See USING THE ON-BOARD CHARGER).

HOW THE MACHINE WORKS

Conventional Scrubbing:

Water and detergent from the solution tank flow to the floor through a manually controlled solution valve. The pad uses the detergent and water solution to scrub the floor clean. As the machine moves forward, the squeegee wipes the dirty solution from the floor into the recovery tank.

ec-H₂O Scrubbing (ec-H₂O Model):

(ec-H₂O—electrically converted water)
Normal water passes through a module where it is oxygenated and charged with an electric current. The electrically converted water changes into a blended acidic and alkaline solution forming a neutral pH cleaner. The converted water attacks the dirt, breaks it into smaller particles, and pulls it off the floor surface allowing the machine to easily scrub away the suspended soil. The converted water then returns to normal water in the recovery tank.

PAD INFORMATION

BACKER PAD (With Retaining Strips)

For best cleaning performance and to avoid damaging the pad driver plate or floor surface, always use backer pad (p/n 9010674) with work pads (Figure 3).

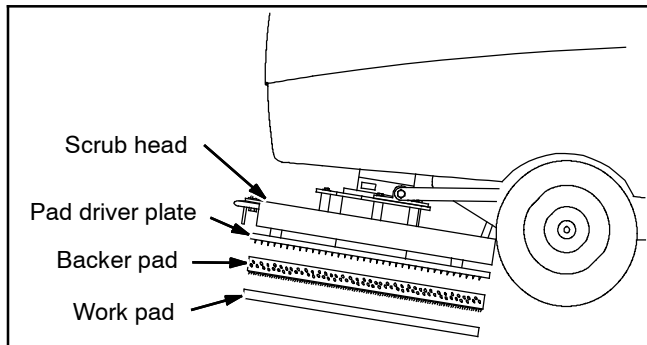

FIG. 3

WORK PADS

For best results, use the correct work pad type for the cleaning application. The following are recommended work pads.

Polishing Pad (White) - Used to maintain highly polished or burnished floors (p/n 1205512, 10 pack).

Buffing Pad (Red) - Used for light duty scrubbing without removing floor finish (p/n 1205513, 10 pack).

Scrubbing Pad (Blue) - Used for medium to heavy-duty scrubbing. Removes dirt, spills, and scuffs (p/n 1205514, 10 pack).

Surface Preparation Pad (Maroon) - Used for very aggressive chemical free removal of floor finish to prepare the floor for re-coating (p/n 1205515, 10 pack).

MACHINE SETUP

ATTACHING SQUEEGEE ASSEMBLY

1. Park the machine on a level surface and remove the key.
2. Lift the squeegee lift lever to the upward position (Figure 4).

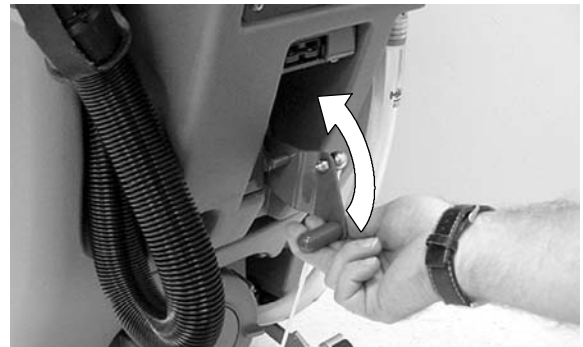

FIG. 4

3. Mount the squeegee assembly to the squeegee pivot bracket as shown (Figure 5). Make sure the knobs are completely seated into the slots before securing knobs.



FIG. 5

4. Connect the vacuum hose to the squeegee assembly. Loop the hose as shown using the hose clip provided (Figure 6).

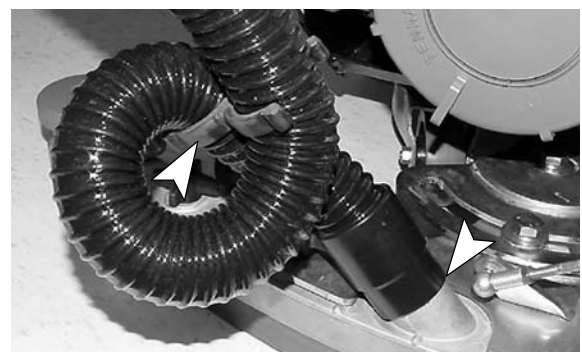

FIG. 6

5. Check the squeegee blades for proper adjustment (See *SQUEEGEE BLADE ADJUSTMENT*).

OPERATION

INSTALLING BACKER PAD AND WORK PAD

NOTE: Refer to the PAD INFORMATION section in this manual or consult your authorized distributor for pad recommendations.

1. Park the machine on a level surface and remove the key.
2. Step down on the scrub head lift pedal to raise the scrub head off the floor (Figure 7).



FIG. 7

3. Align the backer pad with the four edges of the scrub head and install the backer pad onto the bottom of the scrub head (Figure 8).



FIG. 8

4. Align and install the work pad onto the backer pad (Figure 9).



FIG. 9

FILLING SOLUTION TANK

The machine is equipped with a hose fill-port at the rear of the machine, and a bucket fill-port located under the recovery tank (Figure 10). Before accessing the bucket fill-port make sure that the recovery tank is empty.

Fill the solution tank to the "40 L MAX" level on the solution tank sight gauge. When using the bucket fill-port, stop filling when the level reaches the bottom edge of the fill-port (Figure 10).

FOR ec-H₂O SCRUBBING: Use cool clean water only (less than 70°F/21°C). Do not add any conventional floor cleaning detergents, system failure may result.

FOR CONVENTIONAL SCRUBBING: Fill the tank with water, 140°F/60°C maximum. Pour a recommended cleaning detergent into the solution tank according to mixing instructions on the bottle.

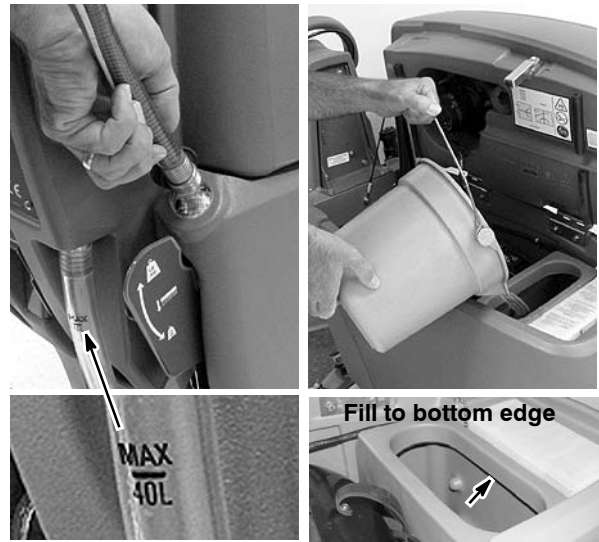

FIG. 10

NOTE: When filling the solution tank with a bucket, make sure that the bucket is clean. Do not use the same bucket for filling and draining the machine.

ATTENTION: For Conventional Scrubbing, only use recommended cleaning detergents. Machine damage due to improper detergent usage will void the manufacturer's warranty.

⚠ WARNING: Fire or Explosion Hazard. Never Use Flammable Liquids.

FOR SAFETY: When using machine, follow mixing and handling instructions on chemical containers.

MACHINE OPERATION

FOR SAFETY: Do not operate machine, unless operator manual is read and understood.

⚠ WARNING: Fire Or Explosion Hazard. Never Operate Machine In Or Near Flammable Liquids, Vapors Or Combustible Dusts.

PRE-OPERATION CHECKS

- Sweep and dust-mop the floor.
- Check the battery meter charge level (See BATTERY METER).
- Check the pad for wear.
- Check the squeegee blades for wear and proper adjustment.
- Make sure the recovery tank is empty and the float shut-off screen is installed and clean.
- For ec-H2O Scrubbing:** Make sure the solution tank is filled with cool clean water only.
- For ec-H2O Scrubbing:** Ensure that all conventional cleaning agents are drained and rinsed from solution tank.

OPERATING THE MACHINE

1. Turn the main power key switch to the on (I) position (Figure 11).



FIG. 11

2. **ec-H2O model:** Press the ec-H2O system switch to the on (I) position (Figure 12).

NOTE: The ec-H2O system indicator light will not turn on until the machine starts scrubbing.

IMPORTANT: NEVER turn the ec-H2O system switch on when conventional scrubbing. Conventional cleaning detergents/restorers may cause failure to the ec-H2O solution system. Drain, rinse and refill solution tank with cool clean water before operating the ec-H2O system.



FIG. 12

3. Lower the squeegee assembly to floor by lowering the squeegee lift lever (Figure 13). The vacuum motor will automatically turn on.



FIG. 13

OPERATION

4. Lower the scrub head to the floor by stepping on the scrub head lift pedal as shown (Figure 14).



FIG. 14

5. Pull the control handle bail backwards to start scrubbing. The machine will propel forward. Push the control handle bail forward to move the machine in reverse (Figure 15).

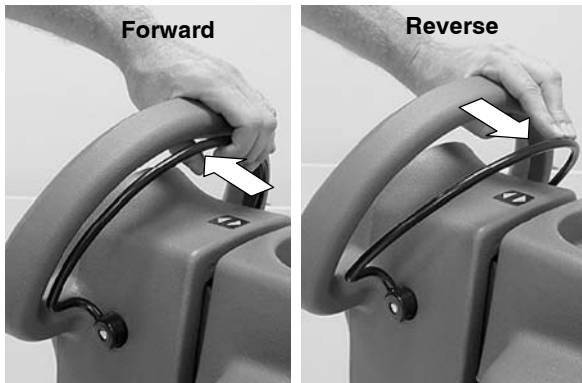

FIG. 15

6. Adjust the speed control knob to a desired scrubbing speed (Figure 16).

NOTE: 45–60 meters (150–200 ft) per minute is the recommended scrubbing speed.



FIG. 16

7. For conventional scrubbing, turn the solution flow control knob to a desired flow rate (Figure 17).

NOTE: For the ec-H2O models, the solution flow rate is fixed and requires no adjustment. The ec-H2O module has optional flow rate settings. If solution flow adjustments are required, contact an Authorized Service Representative.

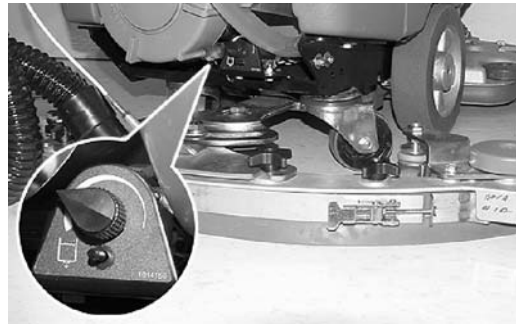

FIG. 17

8. When more pad pressure is needed for heavily soiled areas simply lift the down pressure lever (Figure 18).



FIG. 18

9. To stop scrubbing, release the control handle bail, raise the scrub head and the squeegee.

WHILE OPERATING MACHINE

⚠ WARNING: Fire Or Explosion Hazard. Do Not Pick Up Flammable Materials Or Reactive Metals.

1. Overlap each scrubbing path by 5 cm (2 in).
2. Keep the machine moving to prevent damage to floor finish.
3. Wipe the squeegee blades with a cloth if blades leave streaks. Pre-sweep the area to prevent streaking.
4. Do not operate the machine on inclines that exceed 5%.

FOR SAFETY: When using machine, go slow on inclines and slippery surfaces. Wear non-slip shoes.

5. Pour a recommended foam control solution into the recovery tank if excessive foam appears.

ATTENTION: Do not allow foam to enter the float shut-off screen, vacuum motor damage will result. Foam will not activate the float shut-off screen.

- Use the double scrubbing method for heavily soiled areas. First scrub the area with the squeegee up, let solution set for 3-5 minutes, then scrub the area a second time with the squeegee down.
- When leaving the machine unattended, park the machine on a level surface and remove the key.
- ec-H2O Model:** If an alarm sounds and the ec-H2O system indicator light begins to blink red, the ec-H2O module must be flushed to resume ec-H2O operation (See ec-H2O MODULE FLUSH PROCEDURE) (Figure 19).

NOTE: When the alarm sounds and the light blinks red, the machine will bypass the ec-H2O system. To continue scrubbing, turn the ec-H2O switch off and change over to conventional scrubbing.

ATTENTION: (ec-H2O model) Do not allow solution tank to run dry. ec-H2O module failure may result if operated without water for an extended period.



FIG. 19

ec-H2O SYSTEM INDICATOR LIGHT CODE	CONDITION
Solid green	Normal operation
Blinking red	Flush ec-H2O module
Solid red	Contact Service Center

- Use caution when working near the tile cove (Figure 20) and floor mounted fixtures such as pedestal sinks and other breakable items. Keep the metal scrub head edge away to avoid possible damage to the cove and other breakable items.

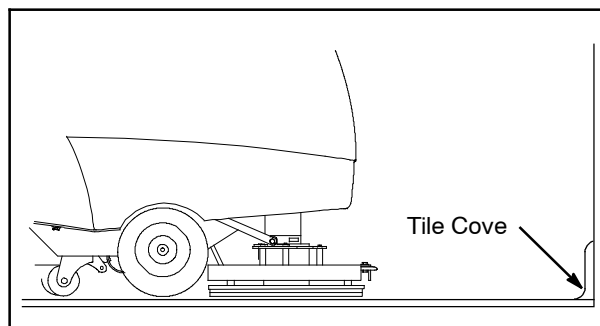

FIG. 20

- When transporting or storing machine, remove the squeegee assembly and hang it on the storage bracket (Figure 21).

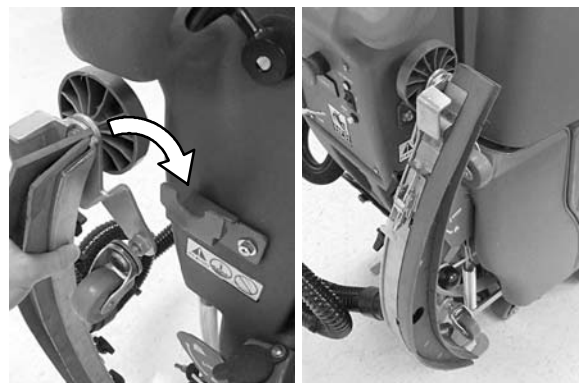

FIG. 21

- Perform the Daily Maintenance procedures after scrubbing (See MACHINE MAINTENANCE).

BATTERY METER

The battery meter displays the charge level of the batteries. When the batteries are fully charged, all indicator lights are lit. As the batteries discharge, the indicator lights will begin to go out from right to left. To prolong the life of the batteries, do not allow the indicator lights to go beyond the discharge level as described below.

NOTE: To prolong the life of the batteries ONLY recharge the batteries when the machine is used for a total of 30 minutes or more.

When the discharge level reaches the last red light (Figure 22), stop scrubbing and recharge the batteries. If the last red light begins to flash, the scrubbing function will shut off automatically. This protects the batteries from total discharge. Drive the machine to the charging area and recharge the batteries immediately.

NOTE: The battery meter also displays machine fault codes. If a fault is detected, the LED bars will flash specific fault codes (See BATTERY METER LED FAULT CODES).

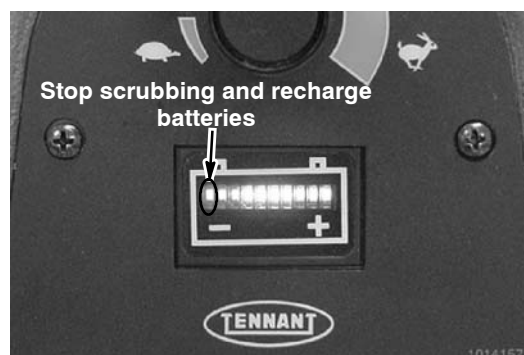

FIG. 22

OPERATION

CIRCUIT BREAKER / FUSES

The machine is equipped with a resettable circuit breaker to protect the pad motor from damage. The circuit breaker button is located on the control panel (Figure 23). If the circuit breaker should trip, determine the cause, allow the motor to cool, and then manually reset the circuit breaker button.

The machine is also equipped with two fuses located inside the control console: 30A Main fuse and a 25A vacuum motor fuse. When replacing a fuse never substitute a higher Amp rated fuse than specified.

Contact an Authorized Service Center for machine repairs.



FIG. 23

HOUR METER

The hour meter records the number of total hours the motor has been powered on. Use the hour meter to determine when to perform recommended maintenance procedures and to record service history (Figure 24).



FIG. 24

DRAINING TANKS

The recovery tank should be drained and cleaned out after every use. The solution tank should be cleaned out periodically to remove any corrosion.

Transport the machine to a draining site, turn the key off and follow the draining instructions below:

FOR SAFETY: Before leaving or servicing machine, stop on level surface, turn off machine and remove key.

DRAINING RECOVERY TANK

1. While holding the drain hose upward, remove the cap and lower hose to drain (Figure 25).

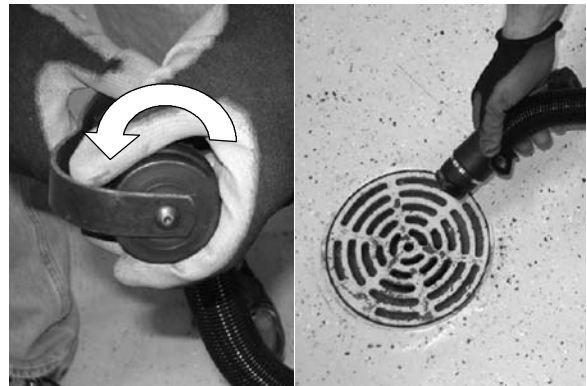

FIG. 25

NOTE: When using a bucket to drain the machine, do not use the same bucket to fill the solution tank.

2. Open the recovery tank cover and rinse out the tank. Use a rag to remove any excess dirt (Figure 26).



FIG. 26

3. Clean the float shut-off screen and debris tray located in the recovery tank (Figure 27).



FIG. 27

DRAINING SOLUTION TANK

1. To drain any remaining water from the solution tank, pull the solution tank level hose off the hose fitting as shown (Figure 28).

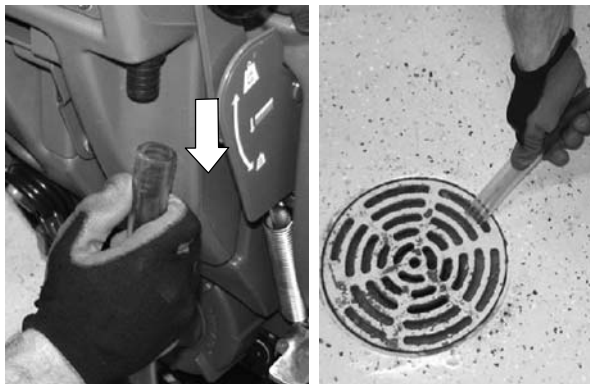

FIG. 28

2. To rinse out the solution tank, remove the clean-out cap at the rear of the machine and spray water, 60°C (140°F) maximum, directly into the two fill-ports located under the recovery tank (Figure 29).

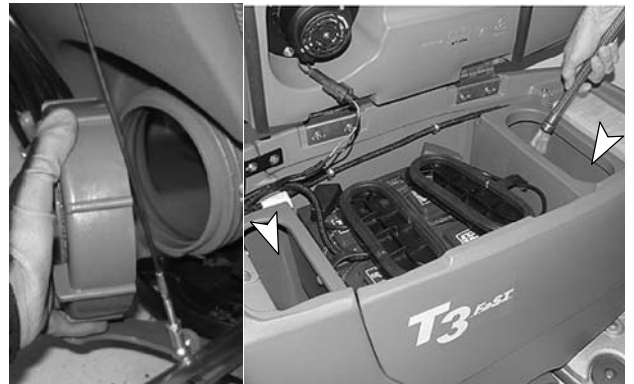

FIG. 29

3. Remove and clean the solution tank filter (Figure 30). Turn the filter counter-clockwise to remove.

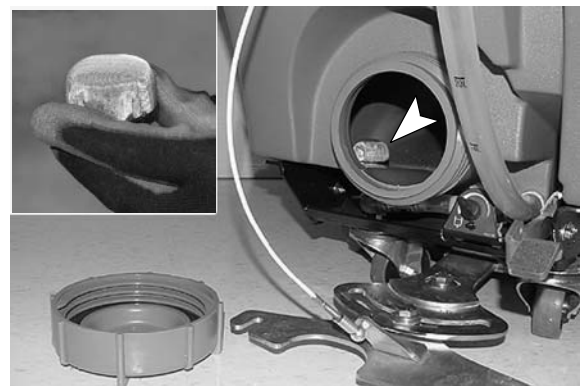

FIG. 30

4. After rinsing out the tank, securely replace the solution tank filter, clean-out cap, fill-port covers and hose.

OPERATION

CHARGING BATTERIES

ATTENTION: To prolong the life of the batteries only recharge the batteries if the machine was used for a total of 30 minutes or more. Do not leave batteries discharged for lengthy periods.

⚠ WARNING: Fire Or Explosion Hazard. Batteries Emit Hydrogen Gas. Keep Sparks and Open Flame Away. Keep Battery Compartment Propped Open When Charging.

FOR SAFETY: When servicing batteries, wear protective gloves and eye protection when handling batteries and battery cables. Avoid contact with battery acid.

The following charging instructions are intended for battery chargers supplied with the machine. Only use a battery charger with the following specifications to prevent battery damage.

BATTERY CHARGER SPECIFICATIONS:

- CHARGER TYPE:
 - FOR SEALED (Gel) BATTERIES
 - FOR WET (Lead Acid) BATTERIES
- OUTPUT VOLTAGE - 24 VOLTS
- OUTPUT CURRENT - 11 AMPS
- AUTOMATIC SHUTOFF CIRCUIT
- FOR DEEP CYCLE BATTERY CHARGING

USING THE ON-BOARD BATTERY CHARGER

IMPORTANT: Make sure the on-board battery charger profile is properly set for your battery type before charging. Failure to properly set will result in battery damage.

To determine your battery type, see battery label. Contact your battery supplier if not specified.

To verify the setting of the charger profile:

Connect the charger cord into an electrical receptacle, open the battery compartment and view the on-board battery charger LED display.

If the LED labeled “GEL” is on, the charger is set for Gel (sealed) batteries. If the LED is off, the charger is set for Wet/lead acid (flooded) batteries (Figure 31).

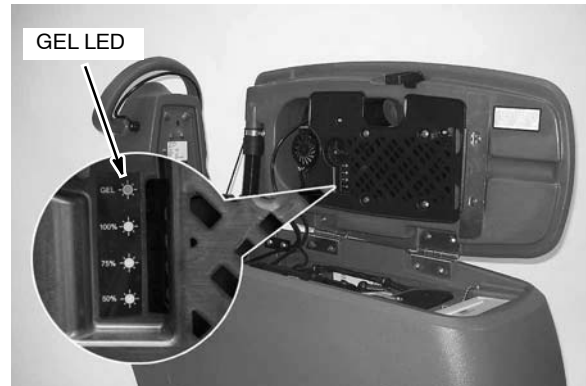

FIG. 31

To change the charger profile:

1. Remove the knob that holds the battery charger mounting panel in position and remove panel to access battery charger (Figure 32).



FIG. 32

2. Unplug the charger cord. Remove the “Charger Profile Selection” panel and position the switch towards the proper setting: “GEL” or “Flooded” (Figure 33).

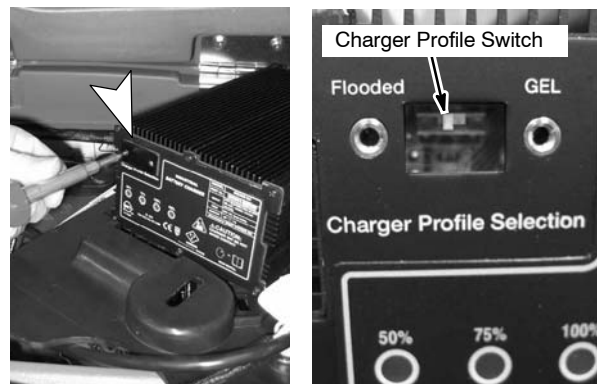

FIG. 33

To charge batteries:

1. Transport the machine to a well-ventilated area for charging.
2. Park the machine on a level surface and turn the key off.
3. If charging wet (lead acid) batteries check the fluid level before charging (See BATTERY MAINTENANCE on page 24).
4. Connect the charger cord into a properly grounded electrical receptacle (Figure 34).

NOTE: The machine will not operate once the battery charger is connected.



FIG. 34

5. The charger will start automatically within a few seconds. The LEDs will display the charging state as described in the following table (Figure 35).

CHARGING STATE LED DISPLAY			
Charging State	50% LED	75% LED	100% LED
0-50% charged	Blinking	Off	Off
50-75% charged	On	Blinking	Off
75-100% charged	On	On	Blinking
100% charged	On	On	On
Abnormal Cycle *	Off	Off	Blinking
Fault detected *	Blinking	Blinking	Blinking

* See the On-board Battery Charger Fault Codes table. When a fault occurs, the charger will also sound an alarm.

FIG. 35

6. Prop up the recovery tank for ventilation when charging (Figure 36).



FIG. 36

7. Once the batteries are fully charged, the charger will stop supplying power, but will continue to monitor the battery voltage. The charger will restart if the batteries self-discharge.

NOTE: The charger may take up to 30 seconds to turn off once the charger cord is disconnected. During this time, the machine will not power up.

The charger cord must also be disconnected for 30 seconds before the charger can be restarted.

OPERATION

ON-BOARD BATTERY CHARGER FAULT CODES

LED FAULT CODE	FAULT	SOLUTION
3 LEDs flash once repeatedly	Loose charger cable connection.	Check charger cable connection.
	Loose or damaged battery cable.	Check battery cable connections.
	Defective Battery.	Replace battery.
3 LEDs flash twice repeatedly	Input voltage is out of range.	Try using a different wall outlet.
3 LEDs flash three times repeatedly	Safety thermostat exceeded maximum internal temperature.	Open battery compartment to promote air circulation or move machine to a cooler climate.
3 LEDs flash four times repeatedly	Output current exceeds a limit.	Disconnect charger cord, wait 30 seconds, then plug back in. If fault continues replace charger or Contact Service Center.
100% LED flashes while the 50% and 75% LED's are off.	Abnormal cycle. Safety timer exceeded the 18 hour charging time.	Battery maintenance required or replace battery.

MACHINE MAINTENANCE

To keep the machine in good working condition, simply follow the daily, monthly and quarterly maintenance procedures.

⚠ WARNING: Electrical Hazard. Disconnect Battery Cables Before Servicing Machine.

FOR SAFETY: When servicing machine, wear personal protection equipment as needed and where recommended in this manual.

DAILY MAINTENANCE (After Every Use)

1. Drain and clean out the recovery tank (Figure 37).



FIG. 37

2. Remove the debris tray and empty (Figure 38)



FIG. 38

3. Remove and clean the float shut-off screen located in the recovery tank (Figure 39).



FIG. 39

4. Drain the solution tank and rinse out the inside with hot water, 60°C (140°F) maximum temperature, as needed (Figure 40)

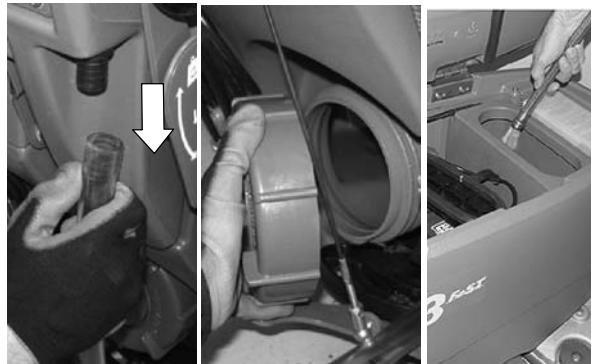

FIG. 40

5. Remove and clean the solution tank filter (Figure 41). Turn the filter counter-clockwise to remove.

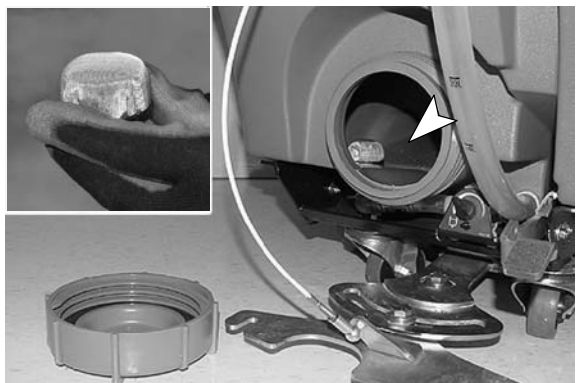

FIG. 41

MAINTENANCE

6. Turn the work pad over or replace when worn (Figure 42).

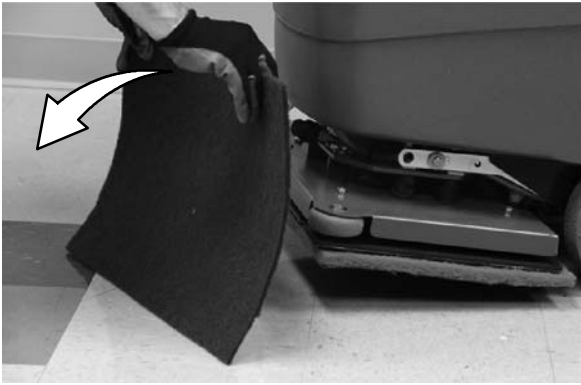

FIG. 42

7. Wipe the squeegee blades clean. When machine is not in use, raise the squeegee assembly off the floor or hang it on the storage bracket (Figure 43).

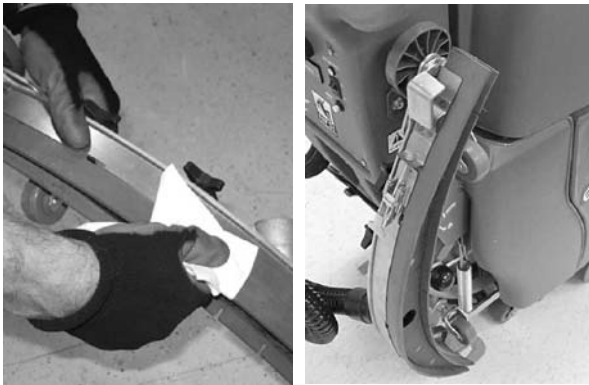

FIG. 43

8. Check the condition of the squeegee blade wiping edge (Figure 44). Rotate blade if worn. (See SQUEEGEE BLADE REPLACEMENT)

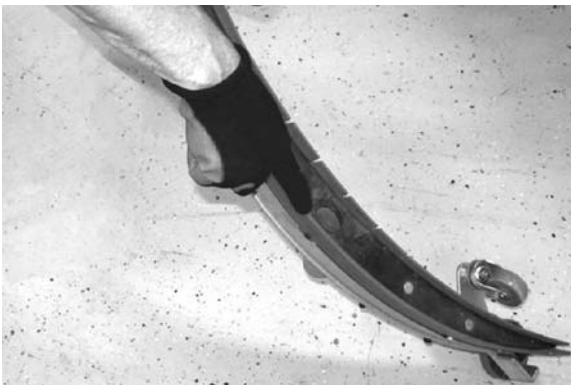

FIG. 44

9. Clean the machine with an all purpose cleaner and damp cloth (Figure 45).

FOR SAFETY: When cleaning machine, do not power spray or hose off machine. Electrical malfunction may occur.



FIG. 45

12. Recharge the batteries after a total of 30 minutes of use or more (Figure 46). (See CHARGING BATTERIES).



FIG. 46

MONTHLY MAINTENANCE (Every 80 hours of use)

1. Clean the battery tops to prevent corrosion (See BATTERY MAINTENANCE).
2. Check for loose battery cable connections.
3. Inspect and clean the recovery tank cover seal (Figure 47). Replace if damaged.



FIG. 47

4. Lubricate all pivot points and rollers with silicone spray then coat with a water resistant grease to maintain smooth operation.
5. Check the machine for loose nuts and bolts.
6. Check the machine for leaks.

MOTOR MAINTENANCE

Contact an Authorized Tennant Service Center for carbon brush replacement.

Carbon Brush Replacement	Hours
Drive Transaxle Motor	750
Vacuum Motor	750
Pad Driver Motor	1200

⚠ WARNING: Electrical Hazard. Disconnect Battery Cables Before Servicing Machine.

ec-H2O MODULE FLUSH PROCEDURE

This procedure is only required when an alarm sounds and the ec-H2O system indicator light begins to blink red.

1. Drain the solution tank and recovery tank of all water.
2. Pour 1 gallon (4 liters) of white or rice vinegar into the solution tank at full strength. Do not dilute.

NOTE: Use **white or rice vinegar** only. The acidity level should be between 4-8%. Do not use other acids for this procedure.

FOR SAFETY: When servicing machine, wear protective gloves and eye protection when handling vinegar.

3. Disconnect the black connector fitting at the scrub head and place the hose into a bucket (Figure 48).

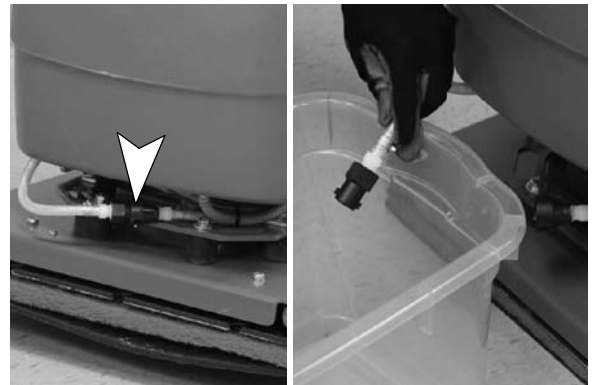

FIG. 48

4. Turn the key to the on (I) position.

MAINTENANCE

5. Press and release the *ec-H2O* module flush switch to start the flush cycle (Figure 49). The module is located under the recovery tank.

NOTE: The module will automatically shut off when the flush cycle is complete (approx. 7 minutes). The module must run the full 7 minute cycle in order to reset the system indicator light and alarm.

Repeat flush procedure if the *ec-H2O* module does not reset. If module fails to reset, contact an Authorized Service Center.



FIG. 49

SQUEEGEE BLADE REPLACEMENT

Each squeegee blade has four wiping edges. When the blades become worn, simply rotate the blades end-for-end or top-to-bottom for a new wiping edge. Replace blade if all four edges are worn.

1. Remove the squeegee assembly from the machine.
2. Loosen the band clamp and remove the band from the squeegee assembly (Figure 50).

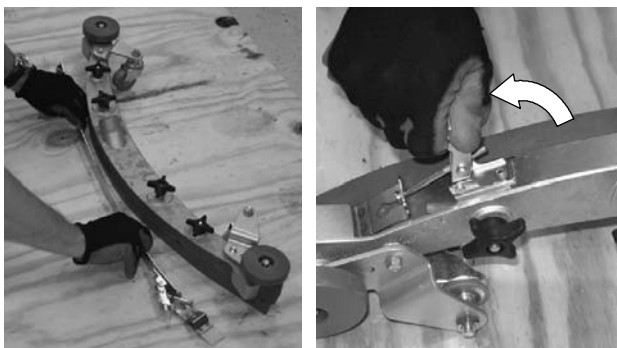

FIG. 50

3. Rotate the rear blade to a new wiping edge and reinstall the band. Make sure the notched edge of the band is facing downward (Figure 51).

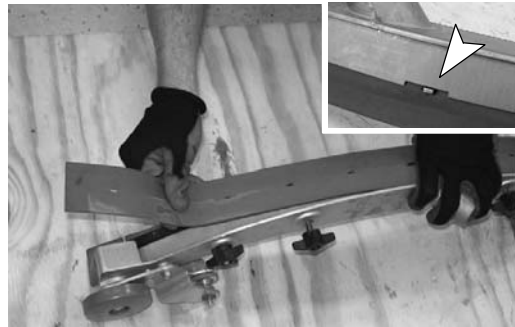

FIG. 51

4. To replace the front blade, remove the rear band and fully loosen the four squeegee assembly knobs, do not remove the knobs. Lift and tilt the retainer plate to access the front blade (Figure 52). Rotate the front blade to a new wiping edge and return the retainer plate. Make sure the retainer plate tabs engage the blade slots. Reinstall the band then retighten the knobs.

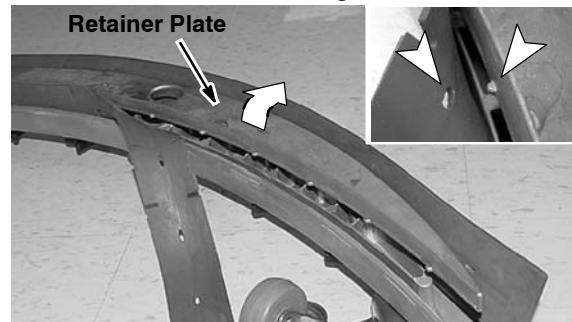

FIG. 52

SQUEEGEE BLADE ADJUSTMENT

The squeegee blade adjustment is factory set, but may require periodic adjustment.

For optimum squeegee blade performance, the squeegee assembly casters must be adjusted to a specified height as described below.

1. To check the squeegee assembly for proper adjustment, remove the squeegee assembly from the machine and place it on a level surface. Measure the distance between the caster and the surface. It should measure approximately 2 mm (1/16") (Figure 53).
2. To adjust the caster height, loosen the top nut and remove the plastic bearing cover to access the adjustment nut. Turn the adjustment nut until properly adjusted (Figure 53). After adjusting, tighten the top nut and replace the plastic bearing cover. Repeat step for the other caster.

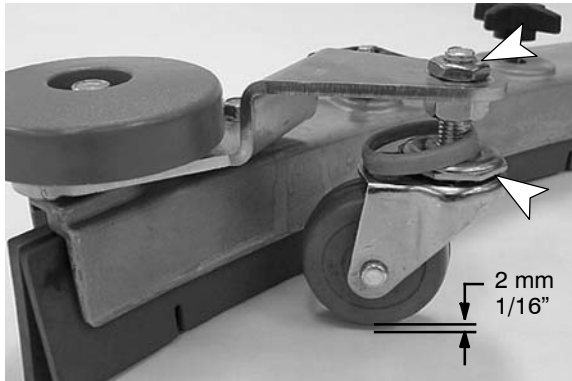

FIG. 53

3. During machine operation, with the casters properly adjusted, the squeegee blades should deflect as shown (Figure 54).

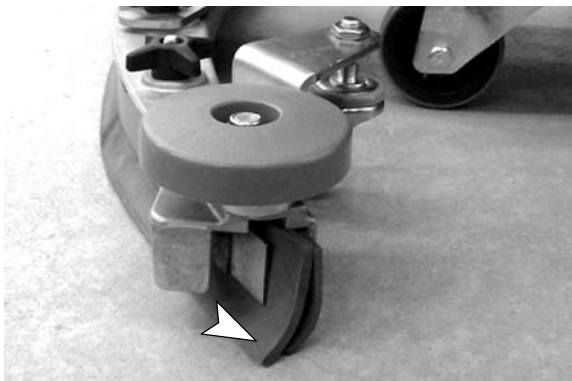

FIG. 54

BATTERY MAINTENANCE (Wet/lead acid batteries)

1. Check battery fluid level frequently to prevent battery damage. The fluid should be at the level shown (Figure 55). Add distilled water if low. **DO NOT OVERFILL**, the fluid may expand and overflow when charging.



CORRECT BATTERY FLUID LEVEL:

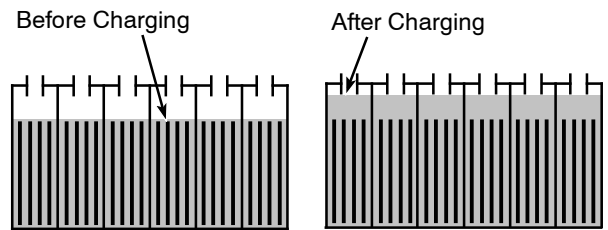

FIG. 55

⚠ WARNING: Fire Or Explosion Hazard. Batteries Emit Hydrogen Gas. Keep Sparks And Open Flame Away. Keep Battery Compartment Open When Charging.

2. Clean the batteries to prevent battery corrosion. Use a scrub brush with a mixture of baking soda and water (Figure 56).

FOR SAFETY: When cleaning batteries, wear protective gloves and eye protection. Avoid contact with battery acid.



FIG. 56

TRANSPORTING MACHINE

When transporting the machine by trailer or truck, be certain to follow the transporting procedure below:

1. Drain machine tanks.
2. Raise the scrub head and hang squeegee on squeegee storage bracket.
3. Load the machine using a ramp that can support the machine weight and person loading it. The maximum ramp incline should not exceed 15% at a ramp length of 12 ft (3.7m).
4. Position the front of machine up against the front of the trailer or truck. Lower the scrub head.
5. Place a block behind each wheel to prevent the machine from rolling.
6. Secure with tie-down straps as shown (Figure 57). It may be necessary to install tie-down brackets to trailer or truck.

FOR SAFETY: When loading/unloading machine onto/off truck or trailer, use a ramp that can support the machine weight and person loading it, do not exceed a 15% ramp incline at a ramp length of 12 ft (3.7m), use tie-down straps to secure machine and block machine wheels.

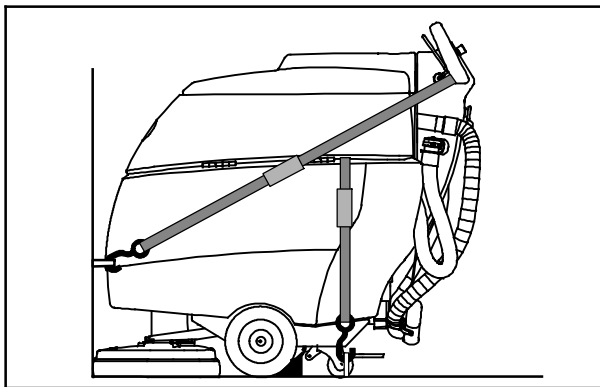

FIG. 57

STORING MACHINE

1. Charge the batteries before storing. Never store the machine with discharged batteries.
2. Drain and rinse the tanks thoroughly.
3. Store the machine in a dry area with the squeegee and scrub head in the up position.
4. Open the recovery tank cover to promote air circulation.

ATTENTION: Do not expose machine to rain, store indoors.

5. If storing machine in freezing temperatures, follow the FREEZE PROTECTION instructions below.

FREEZE PROTECTION

1. Drain the solution tank and recovery tank of all water.
2. Pour 1 gallon / 4 liters of recreational vehicle (RV) antifreeze into the solution tank at full strength. Do not dilute.

FOR SAFETY: Avoid eye contact with antifreeze. Wear safety glasses.

3. Turn the machine power on and operate the solution flow system. Turn the machine off when the red RV antifreeze is visible.

Continue with the freeze protection procedure if machine is equipped with the *ec-H2O* system.

ec-H2O Model:

Press and release the flush switch on the *ec-H2O* module to cycle the antifreeze through *ec-H2O* system (Figure 58). When the antifreeze is visible, press the switch again to turn off the module.



FIG. 58

IMPORTANT: Before operating machine, the antifreeze must be flushed from the module as described below.

If the antifreeze is not properly flushed from the *ec-H2O* system, the *ec-H2O* module may detect an error and not function (*ec-H2O* switch indicator light will turn red). If this occurs, reset key and repeat the flush procedure as described below.

Flushing antifreeze from *ec-H2O* module:

1. Drain the antifreeze from the solution tank into a bucket.
2. Fill the solution tank with cool water until full (See FILLING SOLUTION TANK).
3. Disconnect the black connector fitting at the scrub head and place the hose into a bucket (Figure 59). To access the connector fitting, you may have to remove the front cover from the machine.

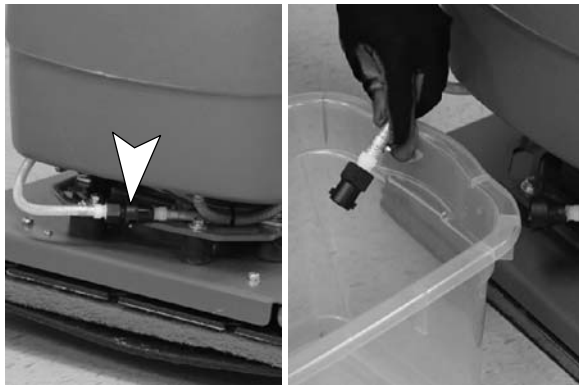

FIG. 59

4. Press and release the *ec-H2O* module switch to flush the antifreeze from the *ec-H2O* system (Figure 58). The module is located under the recovery tank.

When the water turns clear, press the module switch again to stop the flush cycle.

Dispose the antifreeze in an environmentally safe way according to local waste disposal regulations.

5. The machine is now ready for scrubbing.

MAINTENANCE

TROUBLESHOOTING

PROBLEM	CAUSE	SOLUTION
Machine will not operate	Control handle bail not pulled	Pull control handle bail
	Discharged batteries	Charge batteries
	Faulty battery(s)	Replace battery(s)
	Loose battery cable	Tighten loose cable
	Main fuse blown	Replace fuse
	Faulty key switch	Contact Service Center
Battery Meter is flashing	Machine fault has been detected	See BATTERY METER LED FAULT CODES
On-board battery charger will not operate	Plug not connected to power supply	Check plug connection
	Faulty power supply cord	Replace cord
	Fault detected.	See ON-BOARD BATTERY CHARGER FAULT CODES
Pad driver motor will not operate	Scrub head is raised off floor	Lower scrub head
	Battery meter lockout activated	Recharge batteries
	Tripped pad driver motor circuit breaker	Reset circuit pad driver breaker button
	Faulty scrub head (up/down) switch	Contact Service Center
	Faulty Control handle bail switch	Contact Service Center
	Faulty pad driver motor or wiring	Contact Service Center
	Worn motor carbon brushes	Contact Service Center
Machine does not propel	Main fuse blown	Replace 30 Amp fuse
	Faulty relay switch	Contact Service Center
	Faulty transaxle motor or wiring	Contact Service Center
	Worn motor carbon brushes	Contact Service Center
Vacuum motor will not operate	Squeegee is raised off floor	Lower squeegee
	Vacuum motor fuse blown	Replace 25 Amp fuse
	Faulty vacuum motor or wiring	Contact Service Center
	Worn motor carbon brushes	Contact Service Center
Little or no solution flow	Clogged solution tank filter or solution hose	Clean solution tank filter or flush out solution hose
	Solution tank empty	Fill solution tank
	Solution supply lines and / or holes in scrub head distribution tube plugged	Flush solution supply lines / scrub head distribution tube
	Clogged solution valve	Remove valve and clean
	Solution flow control knob set too low (Conventional scrubbing only)	Adjust solution control flow knob (Conventional scrubbing only)
	Loose screw on control knob (Conventional scrubbing only)	Calibrate knob and retighten screw (Conventional scrubbing only)

TROUBLESHOOTING - *continued*

PROBLEM	CAUSE	SOLUTION
Poor water pickup	Recovery tank is full	Drain recovery tank
	Loose drain hose cap	Tighten cap
	Clogged float shut-off screen located in recovery tank	Clean screen
	Clogged squeegee assembly	Clean squeegee assembly
	Worn squeegee blades	Replace or rotate squeegee blades
	Incorrect squeegee blade deflection	Adjust squeegee blade height
	Loose vacuum hose connections	Secure hose connections
	Clogged vacuum hose	Remove clogged debris
	Damaged vacuum hose	Replace vacuum hose
	Recovery tank cover not in place	Properly position cover
	Damaged recovery tank cover seal	Replace seal
	Faulty vacuum motor	Contact Service Center
	Low battery charge	Recharge batteries.
Short run time	Low battery charge	Fully recharge batteries
	Defective batteries	Replace battery
	Batteries need maintenance	See BATTERY MAINTENANCE
	Faulty battery charger	Repair or replace battery charger
	Down pressure lever is set for extra scrub head pressure	Lower down pressure lever
ec-H2O Model: ec-H2O system indicator light blinks red and alarm sounds	Mineral deposit build-up in module	Flush module (See <i>ec-H2O</i> MODULE FLUSH PROCEDURE). If indicator light starts flashing within 1–10 seconds, repeat flush procedure. If indicator light starts flashing after a minute of scrubbing, the water may have low conductivity.
	Low water conductivity	Add 8 ml of salt to every 40 L of water.
ec-H2O Model: ec-H2O system indicator light solid red	Defective module	Contact Service Center
ec-H2O Model: ec-H2O system indicator light does not turn on	Defective light or module	Contact Service Center
ec-H2O Model: No water flow	Clogged module	Contact Service Center
	Defective solution pump	Replace solution pump

MAINTENANCE

BATTERY METER LED FAULT CODES

CODE (Flashing LED Bars)	FAULT	SOLUTION
One	Low voltage shut-off. Scrubbing function stops.	Recharge batteries.
		Check battery connection.
Two	Battery charge level getting low.	Recharge batteries.
Three	Drive motor tripped.	Remove overload condition and reset key.
	Short circuit to drive motor.	Contact Service Center.
Four	Battery lockout.	Recharge batteries immediately.
Eight	Controller tripped.	Contact Service Center.
Ten	High battery voltage reading.	Check battery connections.
No Bars	Sleep mode.	Turn key to restore.
Bars Rippling	Throttle engaged.	Release activation bail.

SPECIFICATIONS

MODEL	T3 Orbital
LENGTH	45 in/1143 mm
WIDTH	20 in/508 mm
SQUEEGEE WIDTH	30 in/763 mm
HEIGHT	43 in/1093 mm
WEIGHT	233 lb/106 Kg
WEIGHT with BATTERIES	403 lb/183 Kg
RECOVERY TANK CAPACITY	15 gal/57 L
SOLUTION TANK CAPACITY	10.5 gal/40 L
DRIVE SYSTEM	Transaxle, 24V, 0.14 hp/0.104 Kw
MINIMUM AISLE TURN	51 in / 1,295 mm
TRAVEL SPEED, MAXIMUM	240 ft / 73 m /min
PRODUCTIVITY RATE (Estimated Actual)	13,050 ft ² / 1,250 m ² h
CLEANING PATH WIDTH	20 in/500 mm
PAD PRESSURE	63 lbs/28.5 Kg Min. - 98 lbs/44.5 Kg Max. 0.23 lb/in ² /0.016 Kg/cm ² Min. - 0.35 lb/in ² /0.025 Kg/cm ² Max.
SOLUTION FLOW RATE	0.4 gpm / 1.5 L/min
PAD DRIVER MOTOR	0.60 hp/0.450 Kw, 2200 pad rpm, 24 V
VACUUM MOTOR	0.5 hp/.373 kW , 300W, 2-stage 5.7, 24 V, 13 A
WATER LIFT - AIR FLOW	40 in/1016 mm - 65 ft ³ / 1.84 L ³ /m
BATTERIES	2- 12 V, 155AH @ 20 hr rate
ON-BOARD BATTERY CHARGER	120/230 VAC, 5.5 A, 50/60 Hz, 24 VDC, 11 A output
RUN TIME PER CHARGE*	3 hours
TOTAL POWER CONSUMPTION	25.5 Amps @ 63 lbs/28.5 Kg pad pressure 26.5 Amps @ 98 lbs/44.5 Kg pad pressure
VOLTAGE DC	24 VDC
PROTECTION GRADE	IPX3
DECIBEL RATING AT OPERATOR'S EAR, INDOORS.**	< 70 dB(A)
VIBRATION AT CONTROLS	<8.2 ft/s ² / <2.5 m/s ²
GRADE LEVEL, MAX.	Scrubbing 5% Transporting 8% Ramp (tanks empty) 15%

* Run times are based on Continuous Scrubbing Run Times.

** Sound levels (ISO 11201) as recommended by the American Association of Cleaning Equipment Manufacturers (AACEM) and OSHA.

ec-H2O SYSTEM MODEL	
PRODUCTIVITY RATE Estimated Actual	13,500 ft ² / 1,255 m ² /h
SOLUTION PUMP	24 Volt DC, 3.5 A, 1.5 gpm/5.6 L/min open flow, 60 psi/4.13 Bar bypass setting
SOLUTION FLOW RATE*	0.15 gpm/0.56 L/min (standard)
	0.19 gpm/0.72 L/min (optional)
	0.25 gpm/0.95 L/min (optional)

* If the optional solution flow rates are required, contact an Authorized Service Center.

SPECIFICATIONS

MACHINE DIMENSIONS

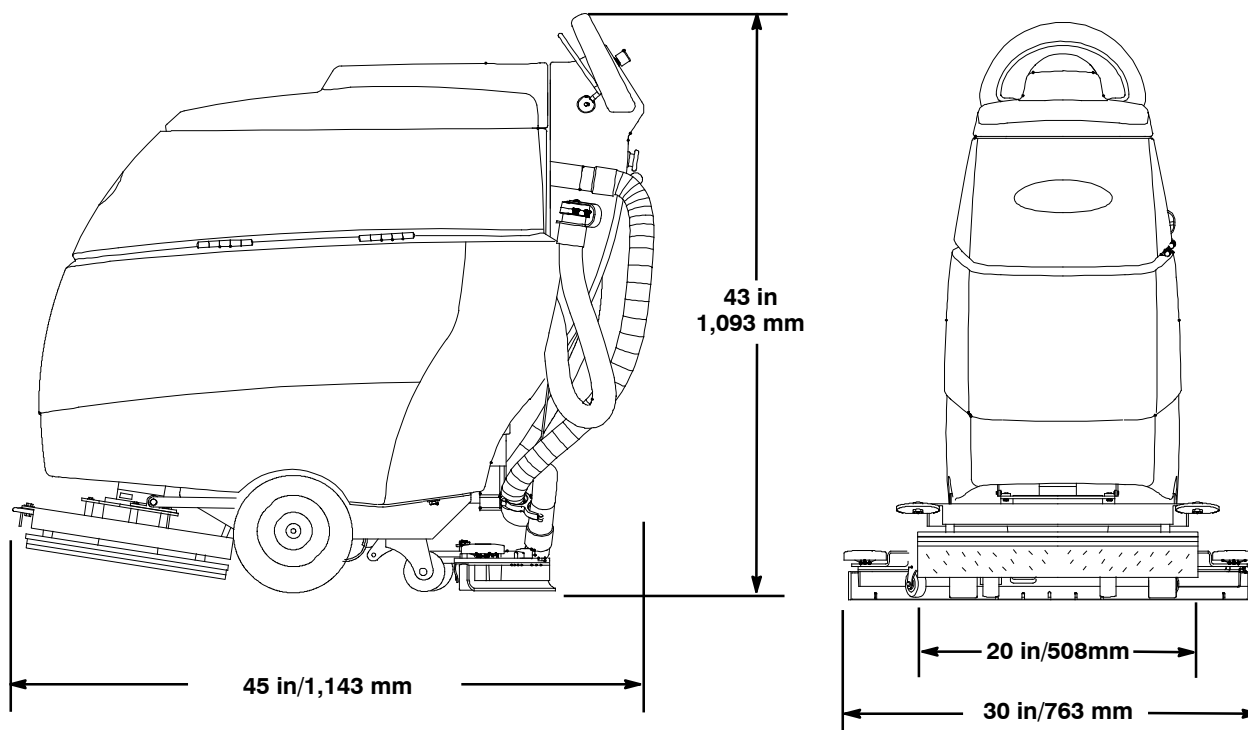

356202